



# התאטרון The Theater

The project offers a different organization of the theater structure. By expanding the performance space, it aims to facilitate meetings between the audience and the creators.

The Theater project is located in Park HaHorshot at the intersection of Kibbutz Galuyot and Shoken streets. The project aims to transform the theater building from a typologically segregated linear structure (comprising Front of House, House and Back of House) to a non-linear flexible structure whose various parts are defined according to the performance taking place. The project combines the formal theater structure with the dynamic (empty) approach. The sequence of spaces offered by the interweaved

building parts and the reconnection of the halls back to the outside Invite the artists to create and develop a variety of performances. The environment, an inherent part of the building, can be used and 'play a role' in the performances when needed. The project's urban development focuses on linking Park HaHorshot to Tel-Aviv and Jaffa while emphasizing the differences and uniqueness characterizing the area.

- 1. Acting Workshops
- 2. Library
- 3. Commercial Uses
- 4. Hall 01
- 5. Production Hangar
- 6. Coffee Shop
- 7. Storage- Costumes and Scenery
- 8. Offices
- 9. Hall 02
- 10. Dining
- 11. Passage To The Park
- 12. Hall 03
- 13. Hall 04
- 14. Pre-Stage
- 15. Rehearsal Rooms
- 16. Hall 05

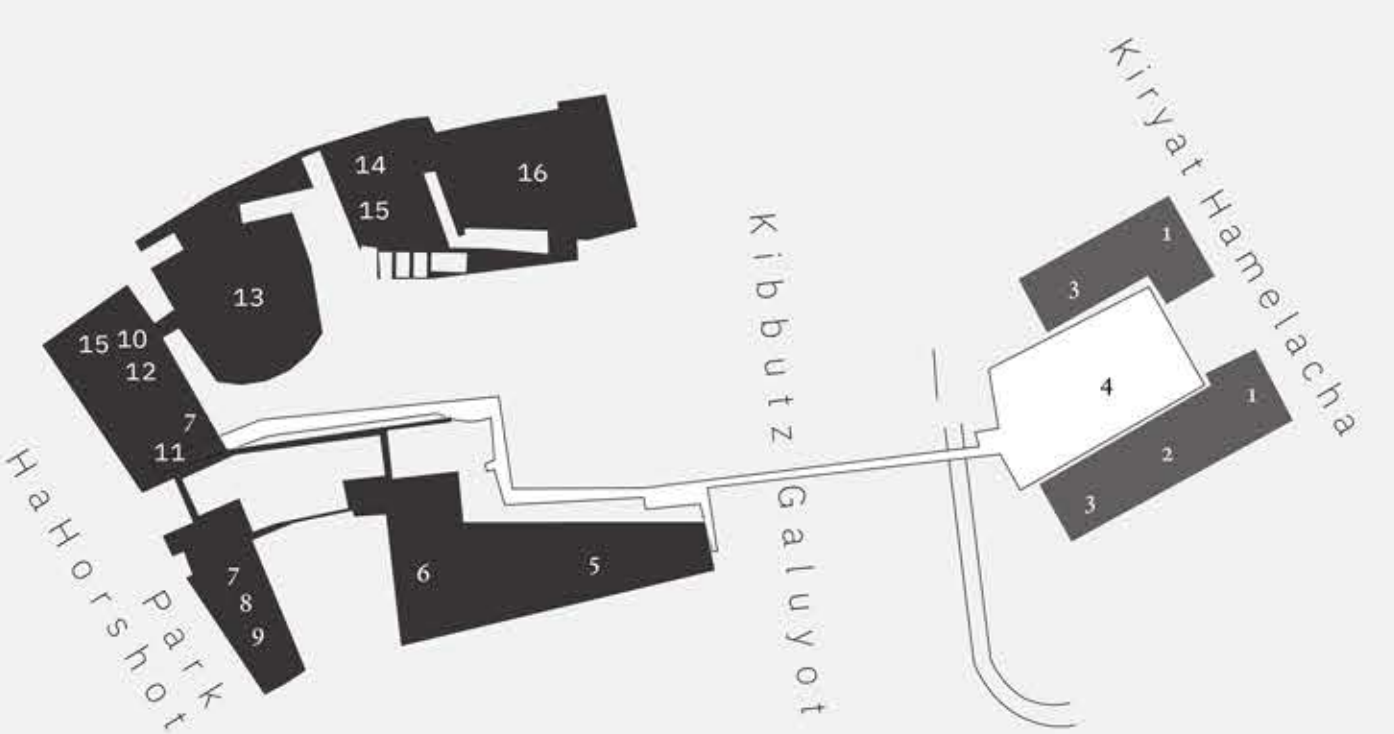

## Programme

**Tower Theater**  
Spiral Motion of Audience and Stages

**Woven Theater**  
Alternately Changing Roles Between Setting, show and the Audience

**World Theater**  
Expansion of Stage - a Walkable Space

## Theater Research

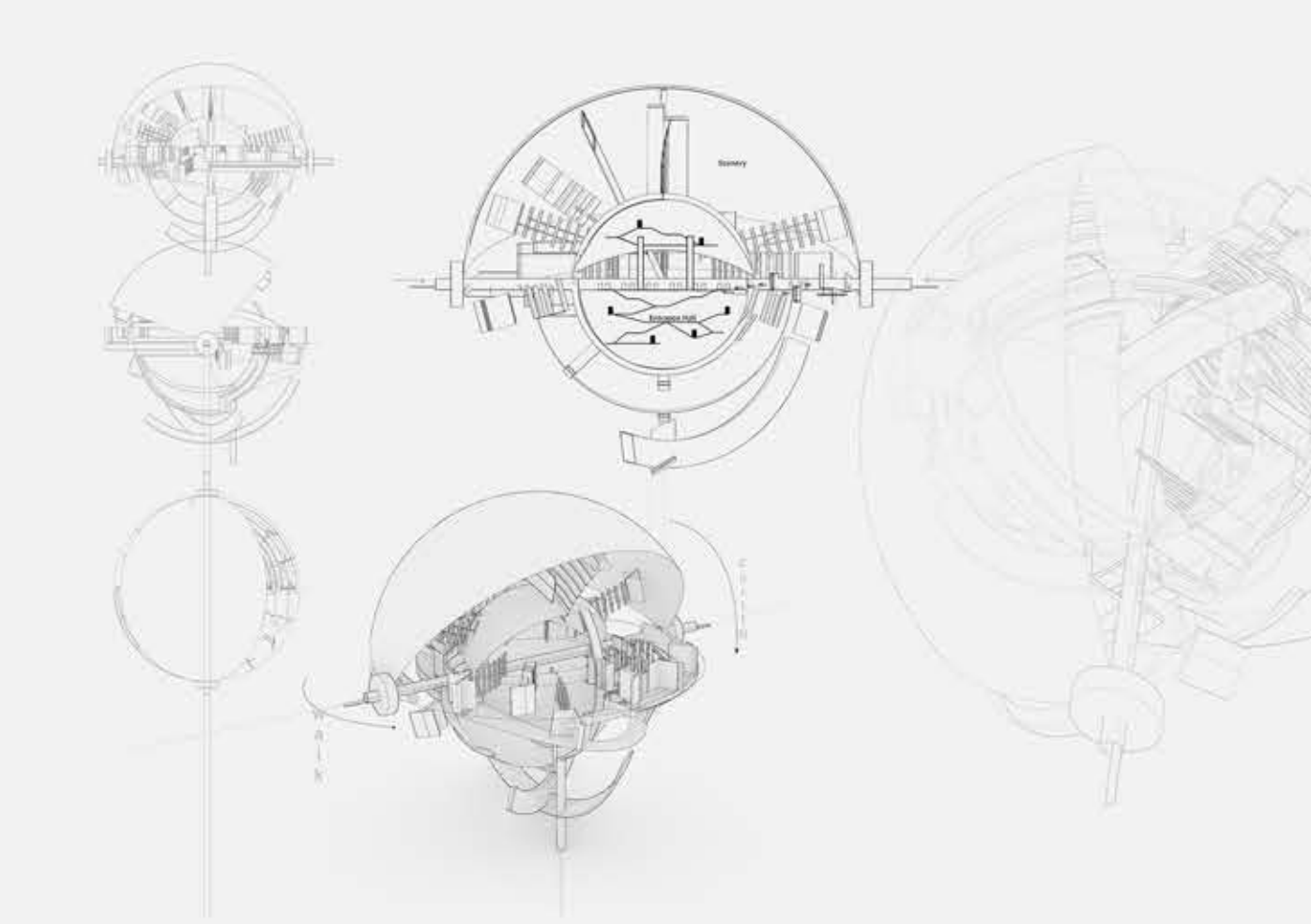
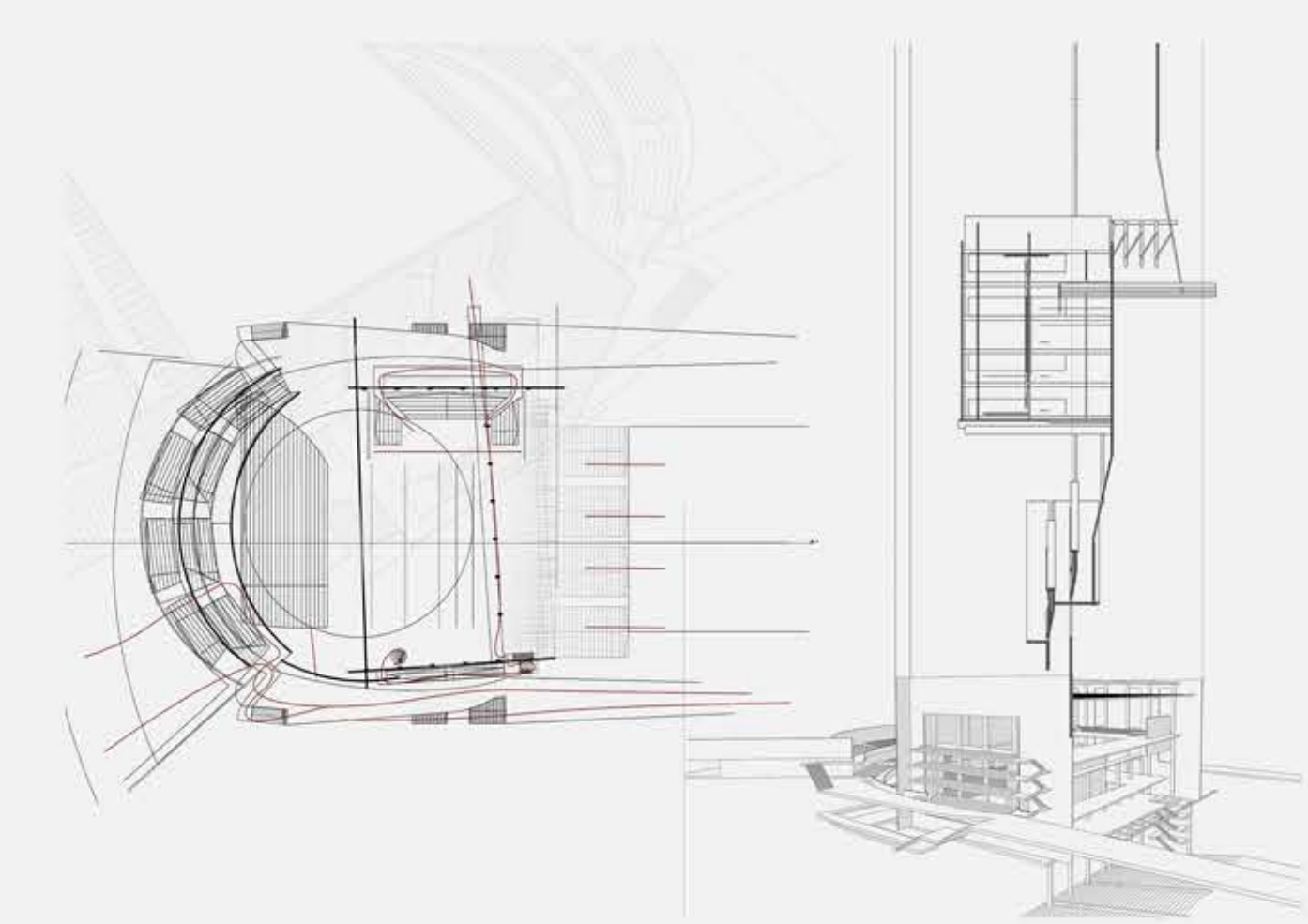
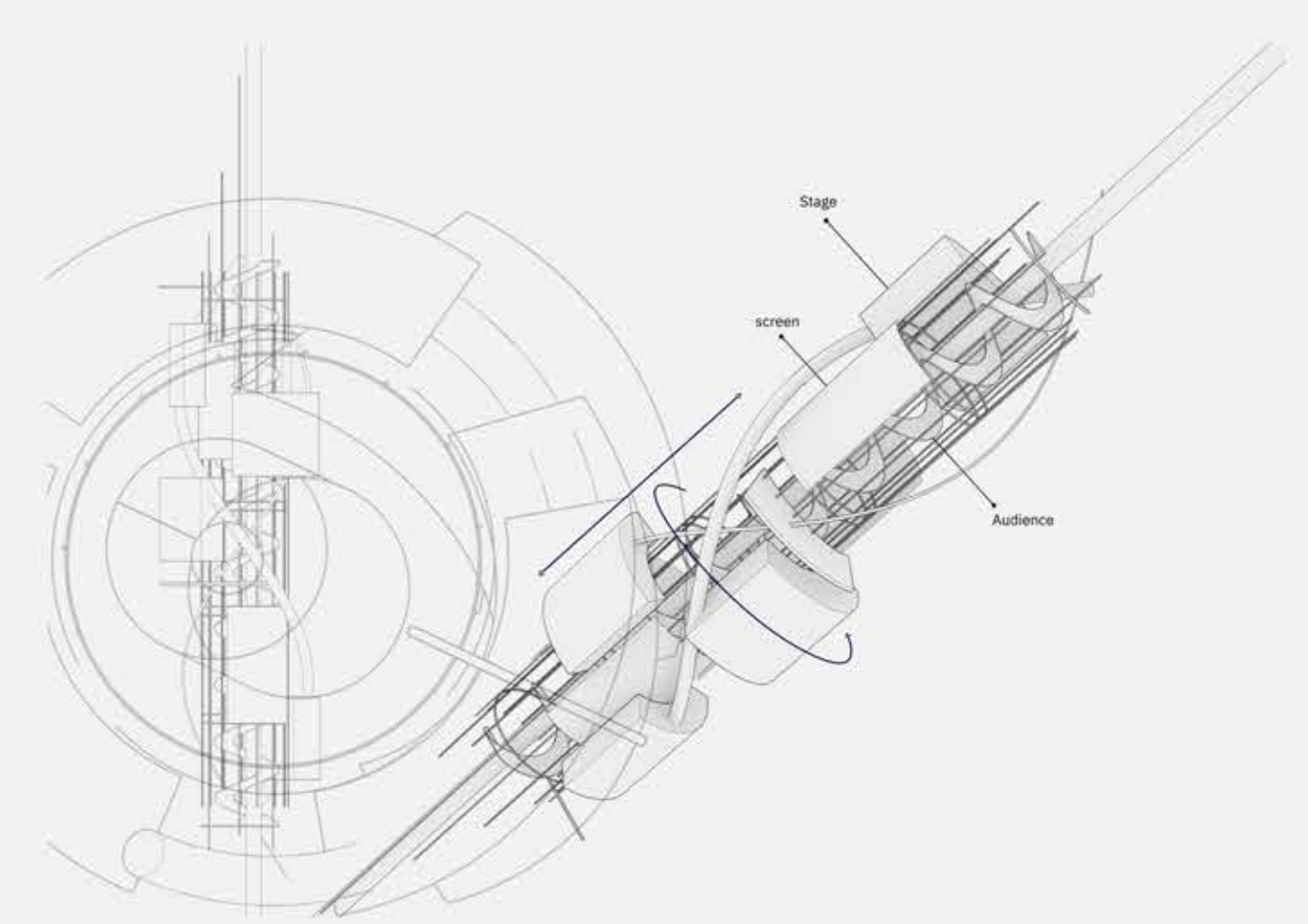

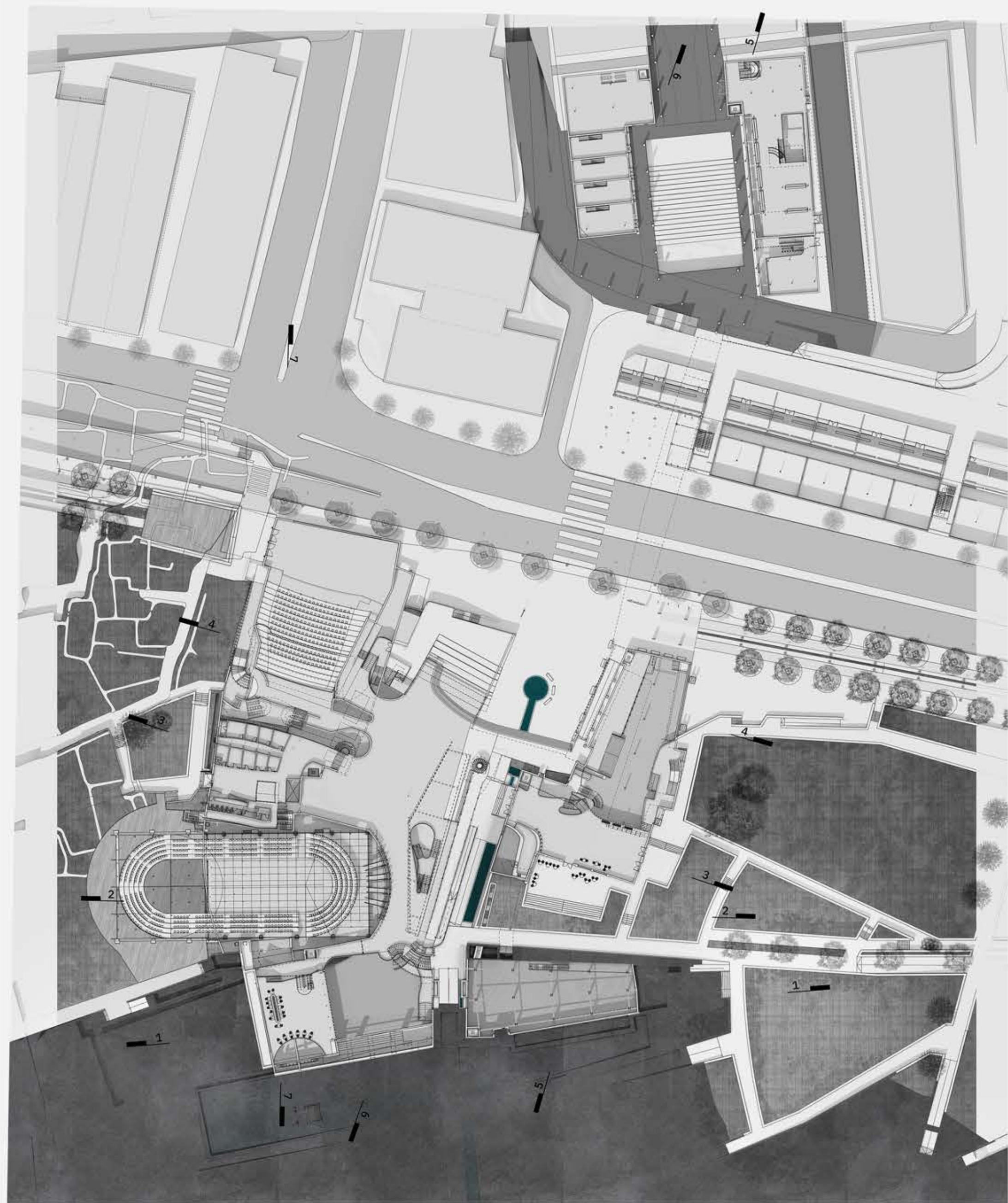

Ground Floor Plan

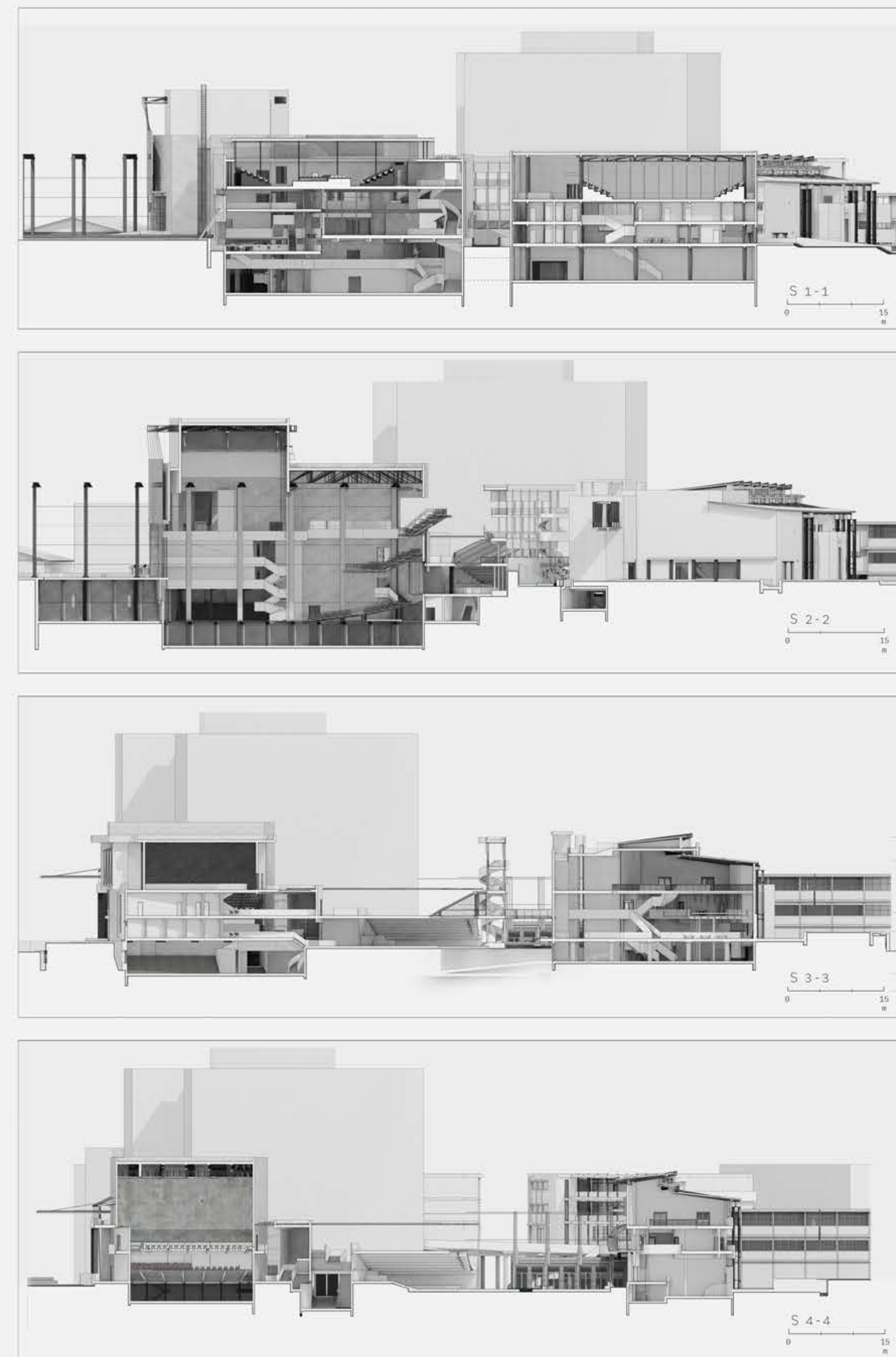

Cross Sections

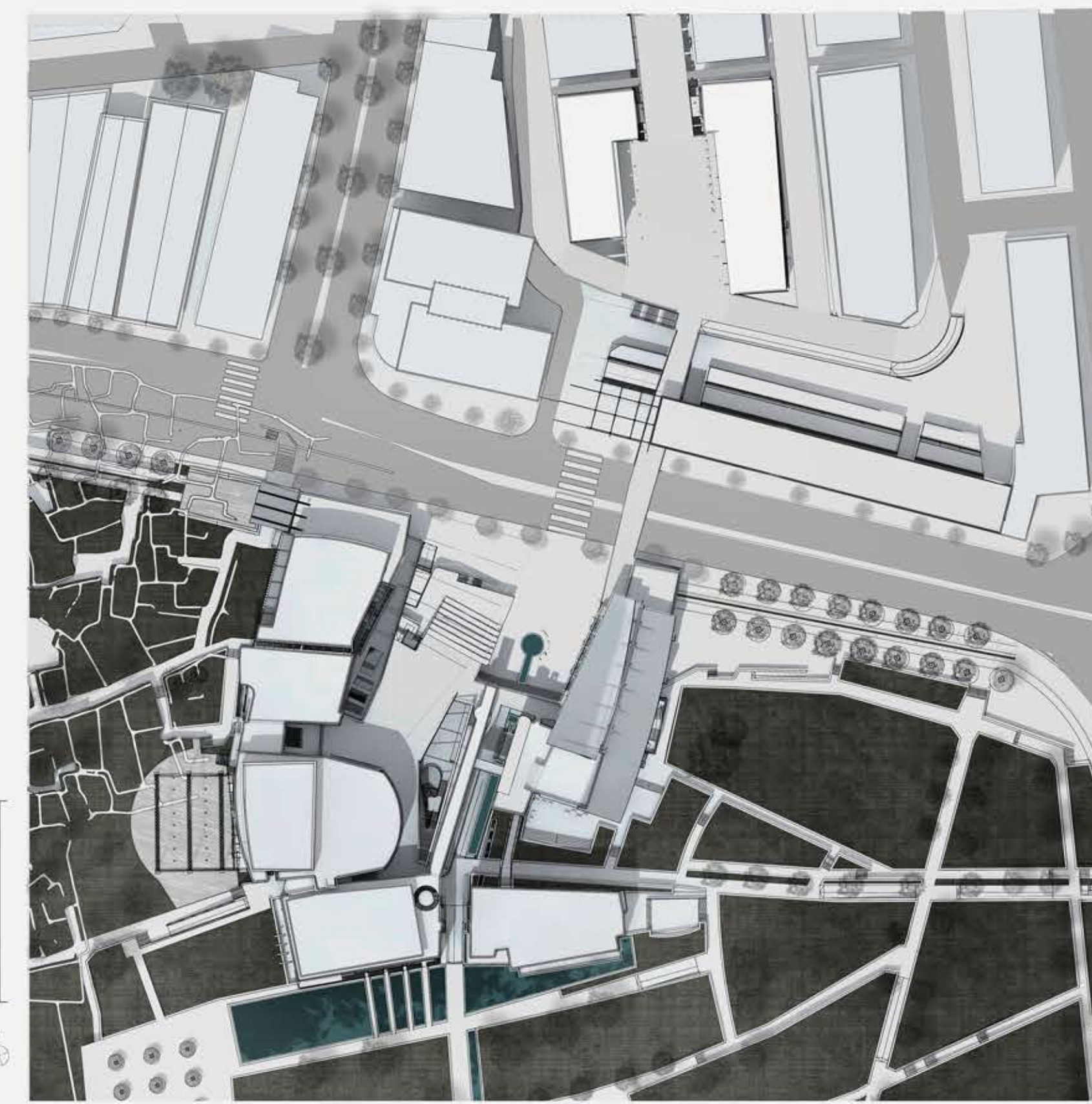

Roof Plan



Area Master Plan

Rendering - Production Hangar & Entrance



Project Drawings

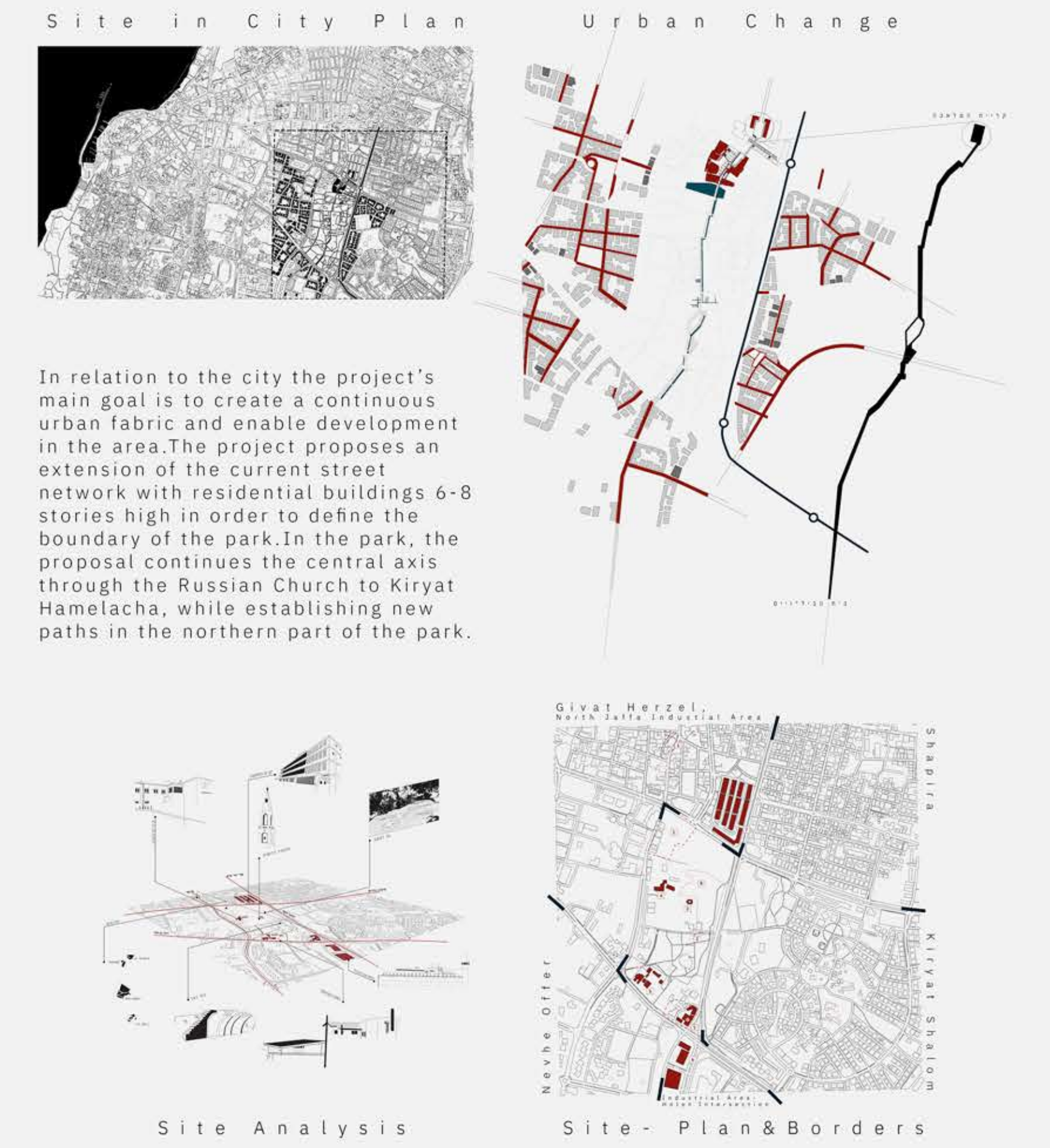

Urban Diagrams

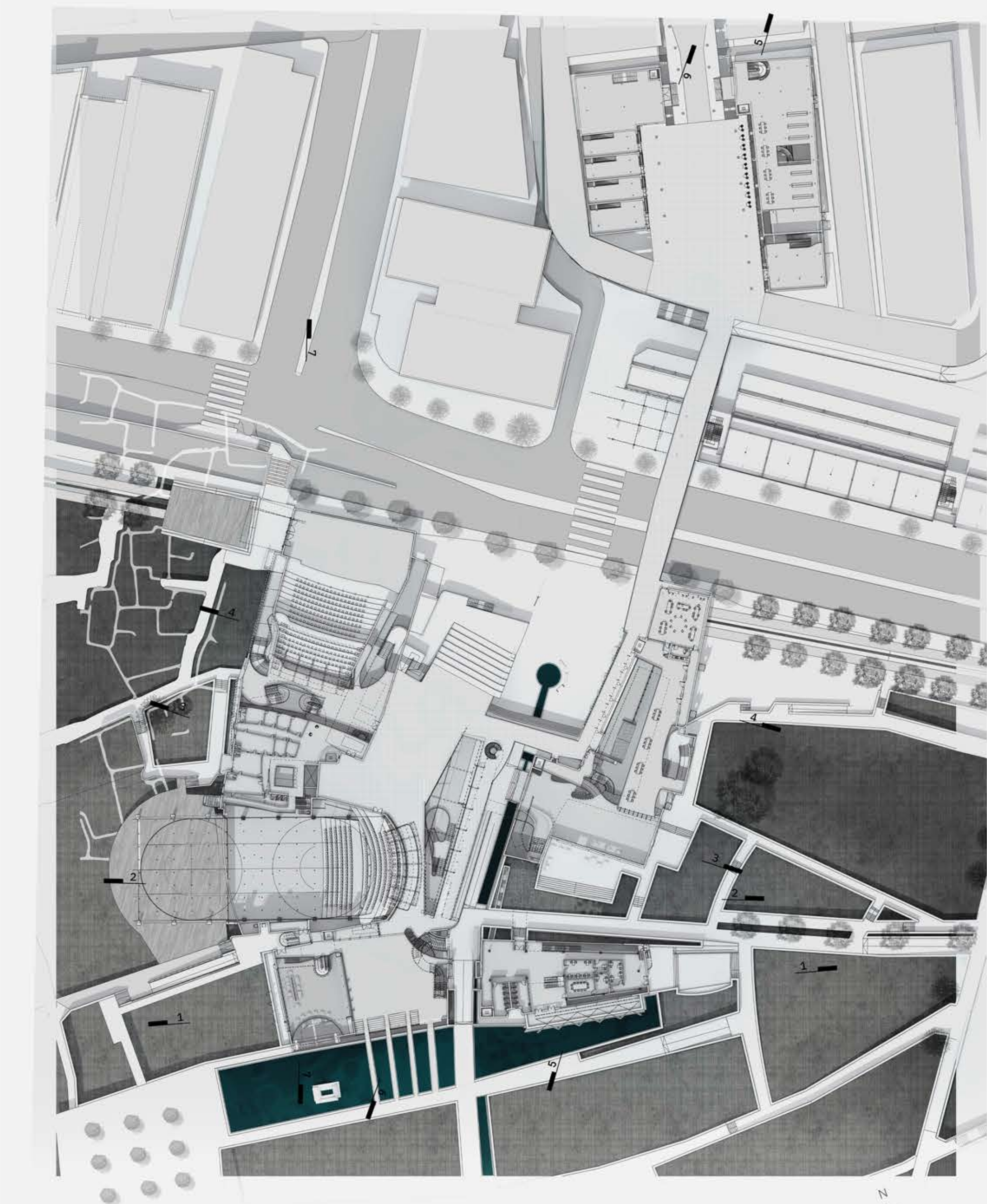

Second Floor Plan



Sections

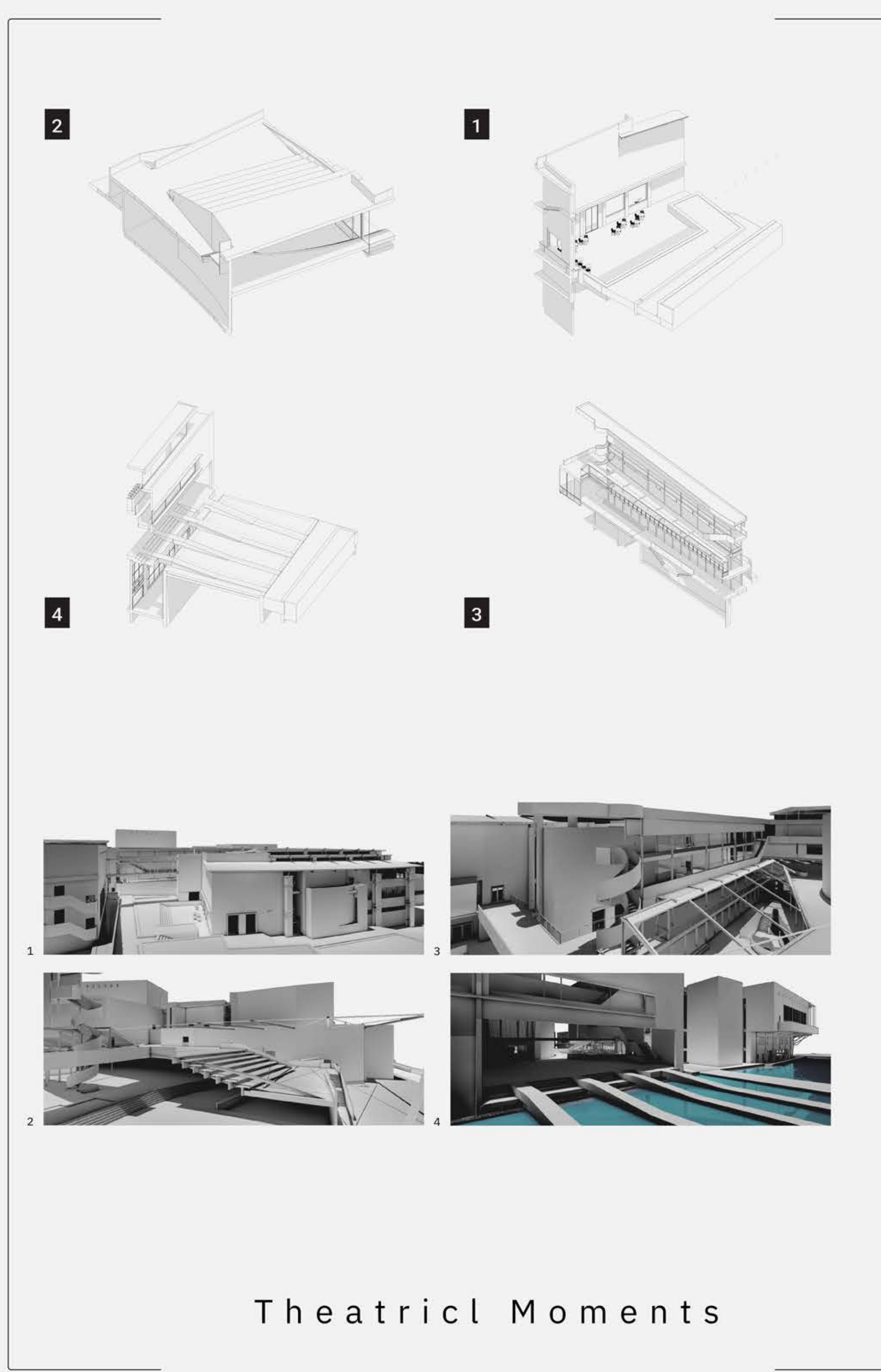

Theatrical Moments

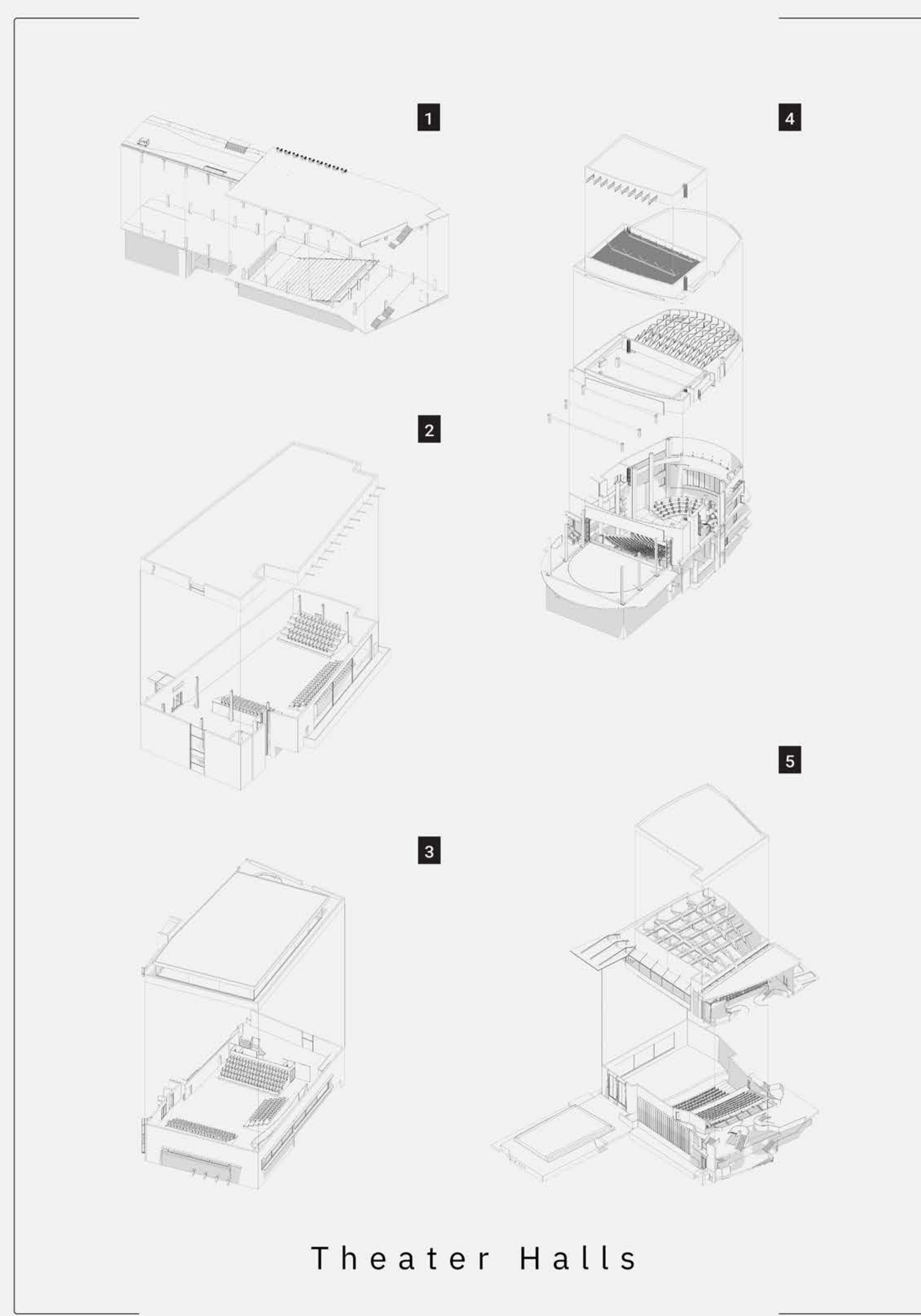

Theater Halls

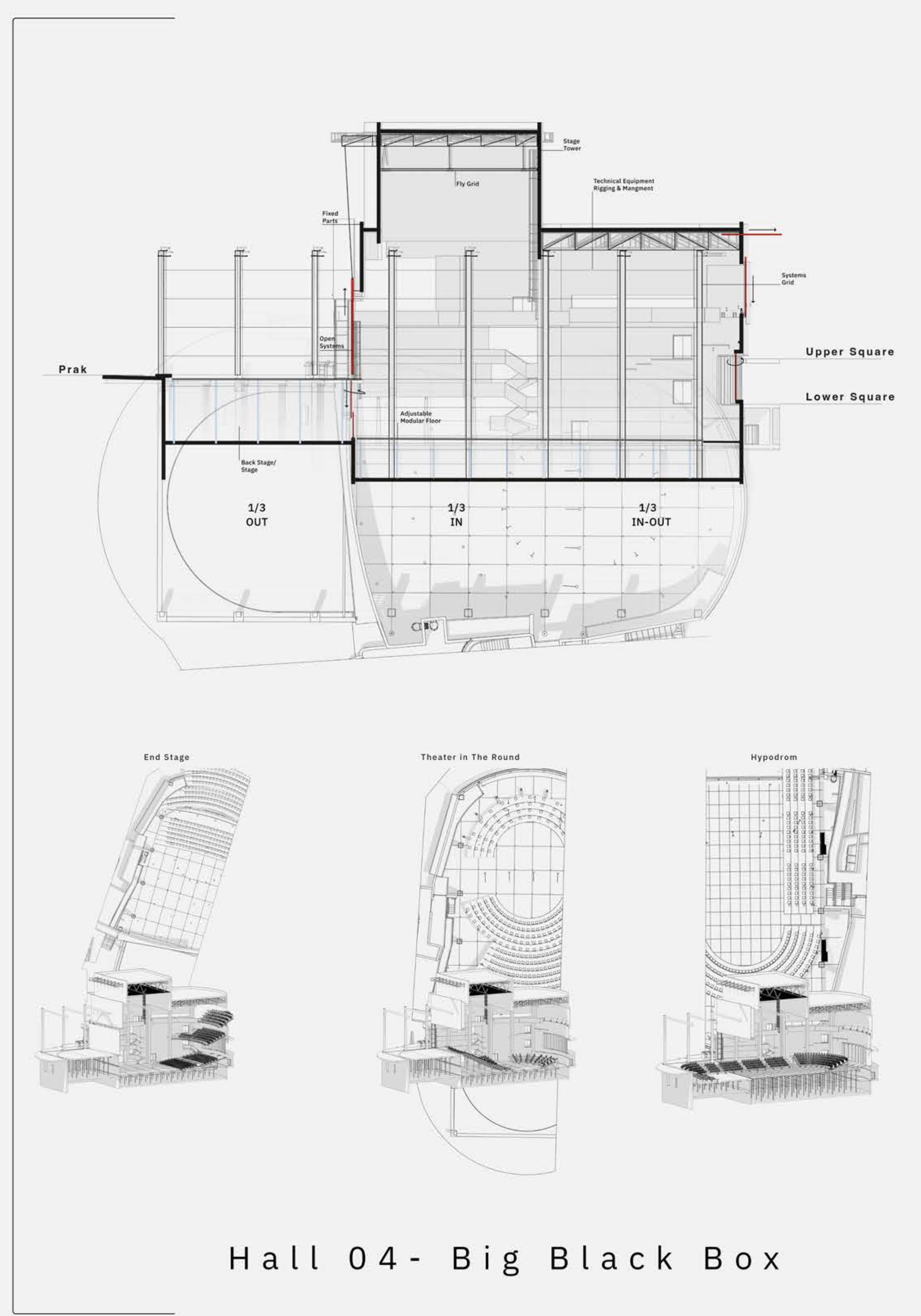

Hall 04- Big Black Box



Rendering- Hall 05

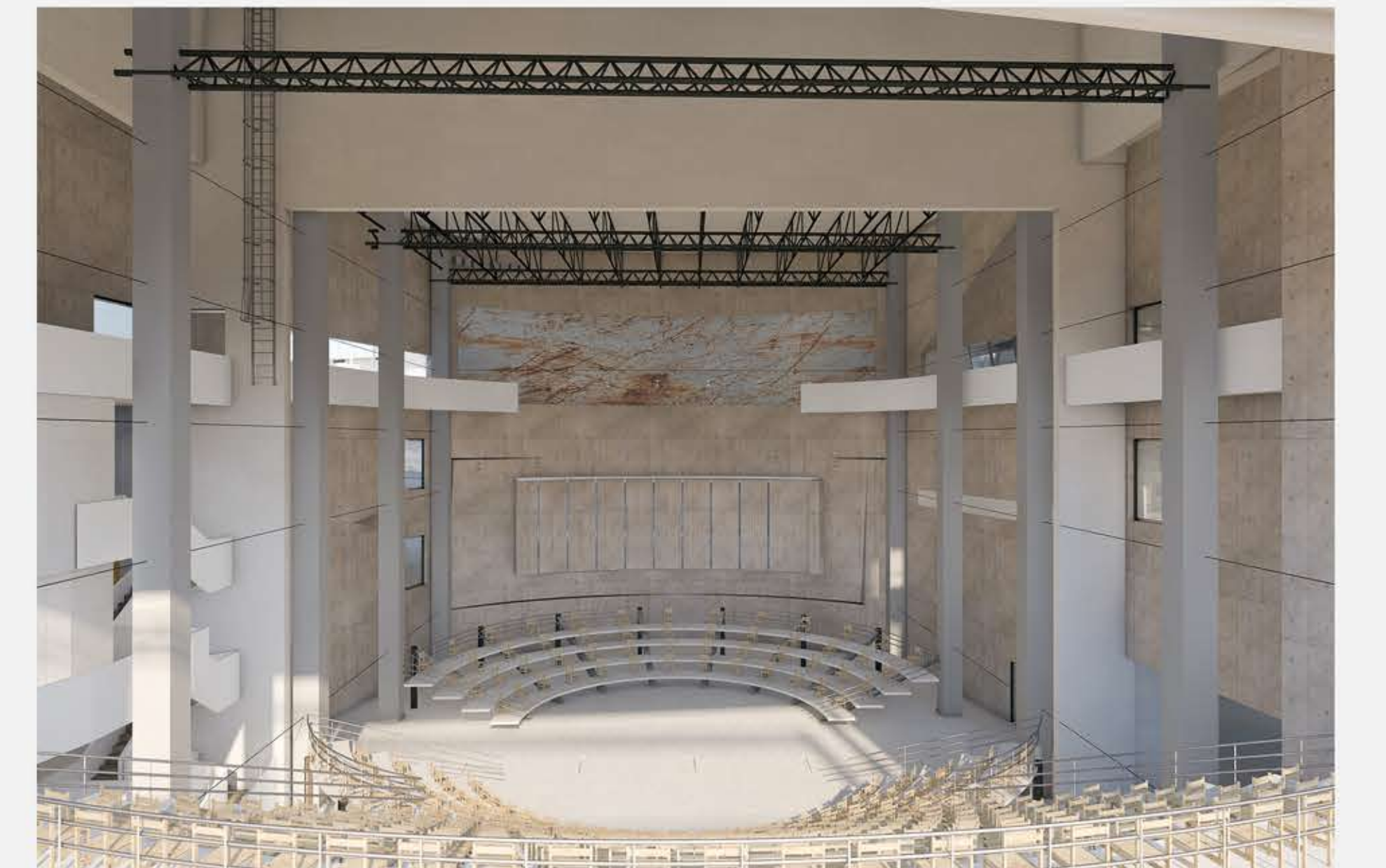

Rendering - Hall 04

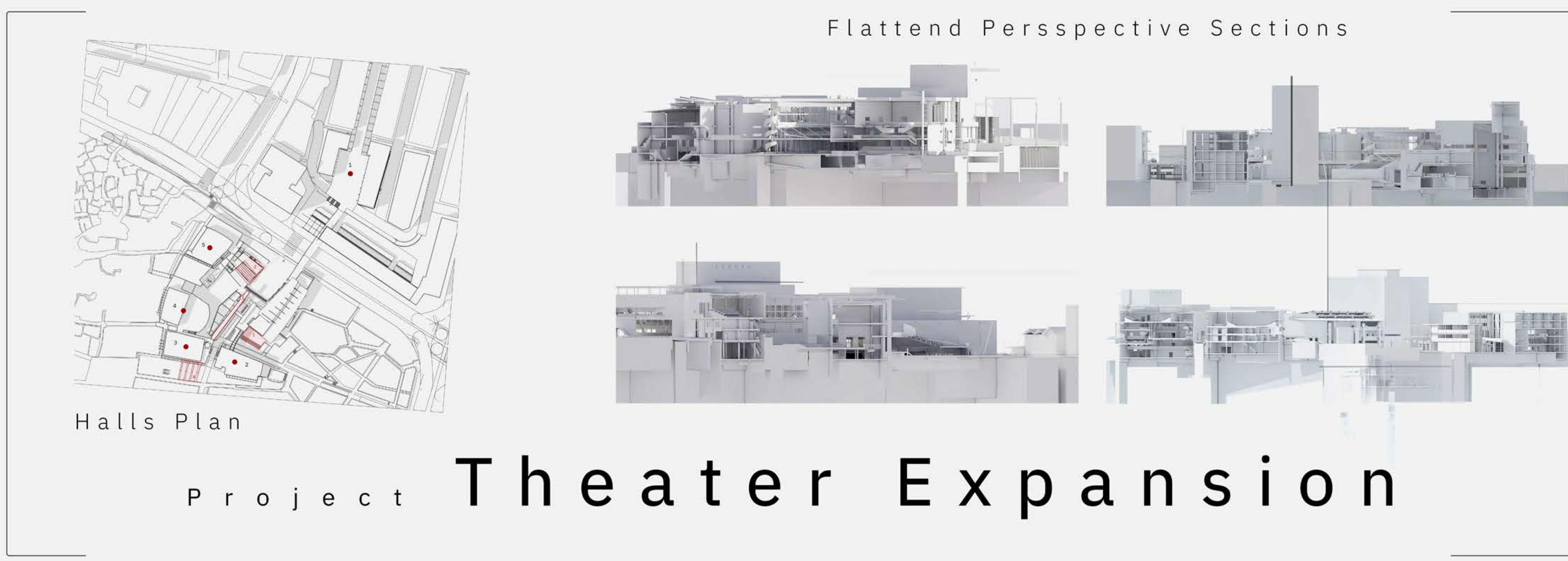

Flattened Perspective Sections

Halls Plan

# Project Theater Expansion

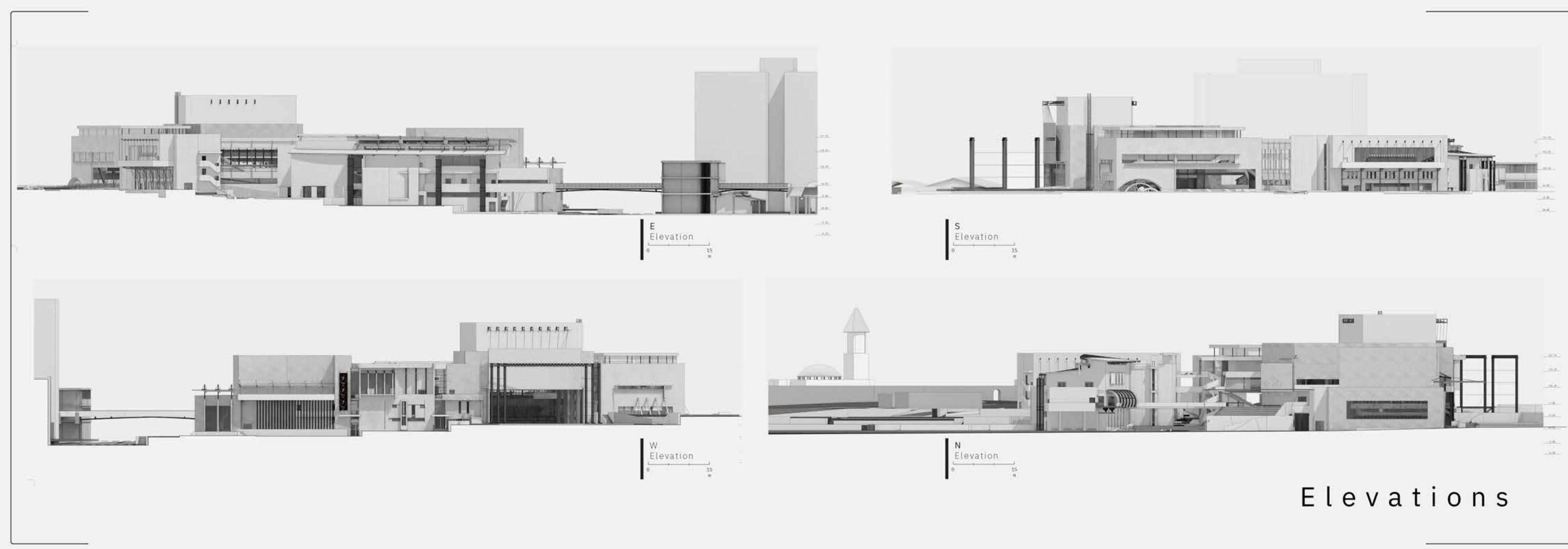

Elevations

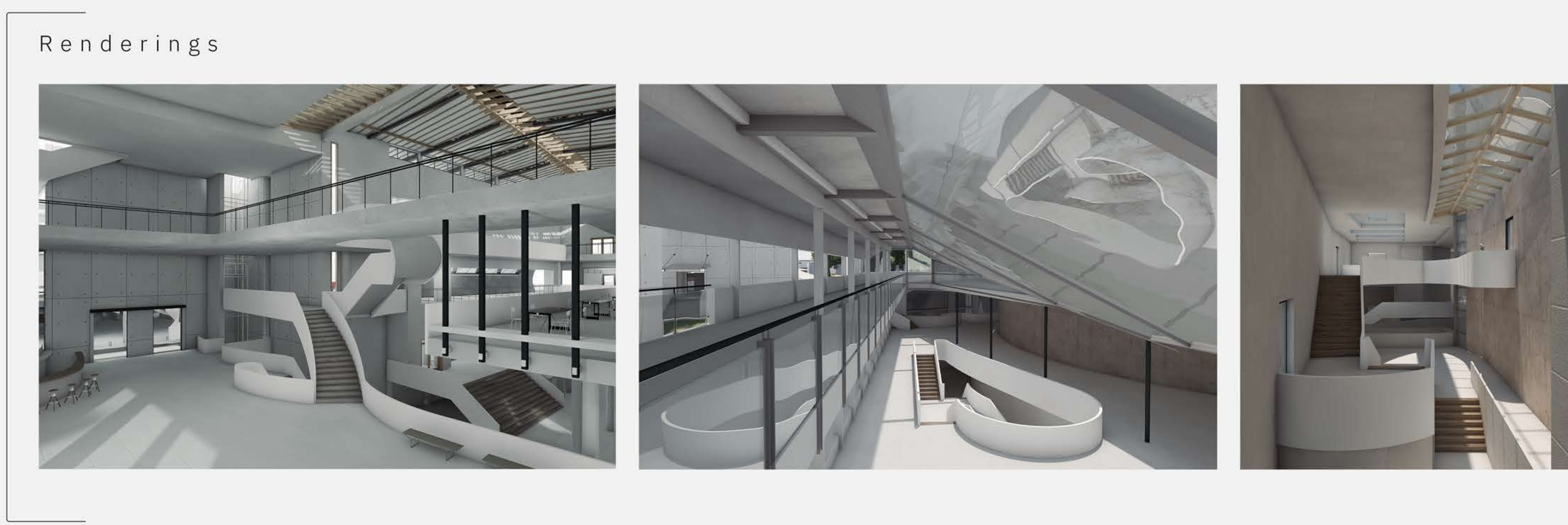

Renderings

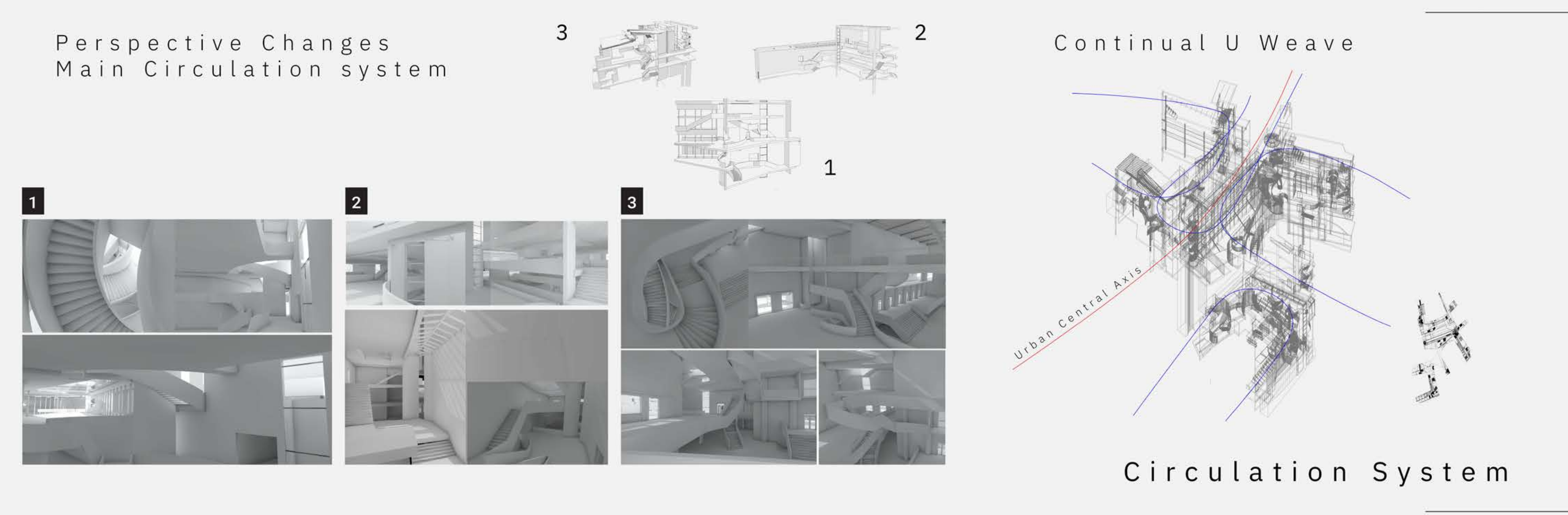

Perspective Changes Main Circulation system

Continual U Weave

Circulation System