

Kibbutz Anew

Planning in Four Acts

Be'eri, my home kibbutz, is a place whose ideological and spatial composition is in question.

On the verge of privatization, between an impractical past and an alienated future, the current moment is characterized with uncertainty and ontological confusion - an identity crisis.

My project seeks a way out of the imaginary dichotomy between disintegration and stasis by following minor details, working from within the community and observing through my position as both planner and civilian, local and outsider, subjective and objective.

Viewing the kibbutz as a complex system of objects, stories, processes and interactions, I lay out four planning systems, re-evaluating fundamental aspects of kibbutz life to formulate an alternative future.

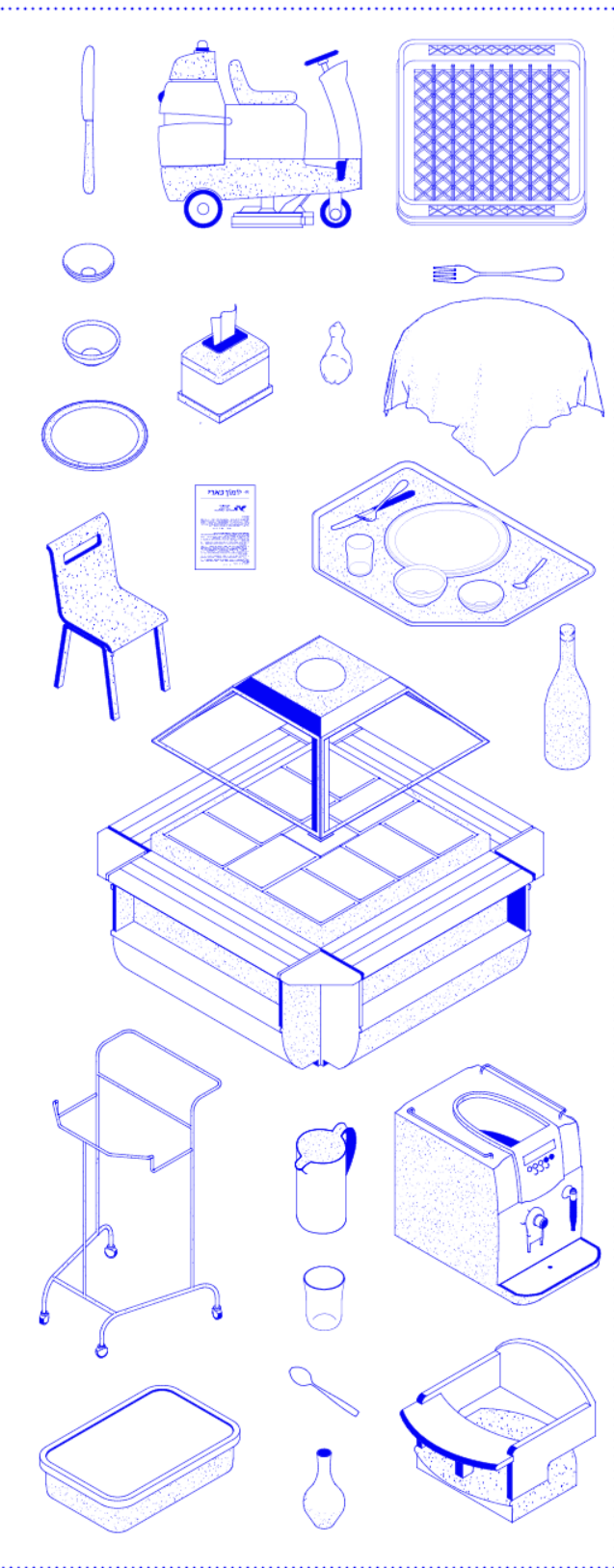

Addressing communality through
Food: Act I

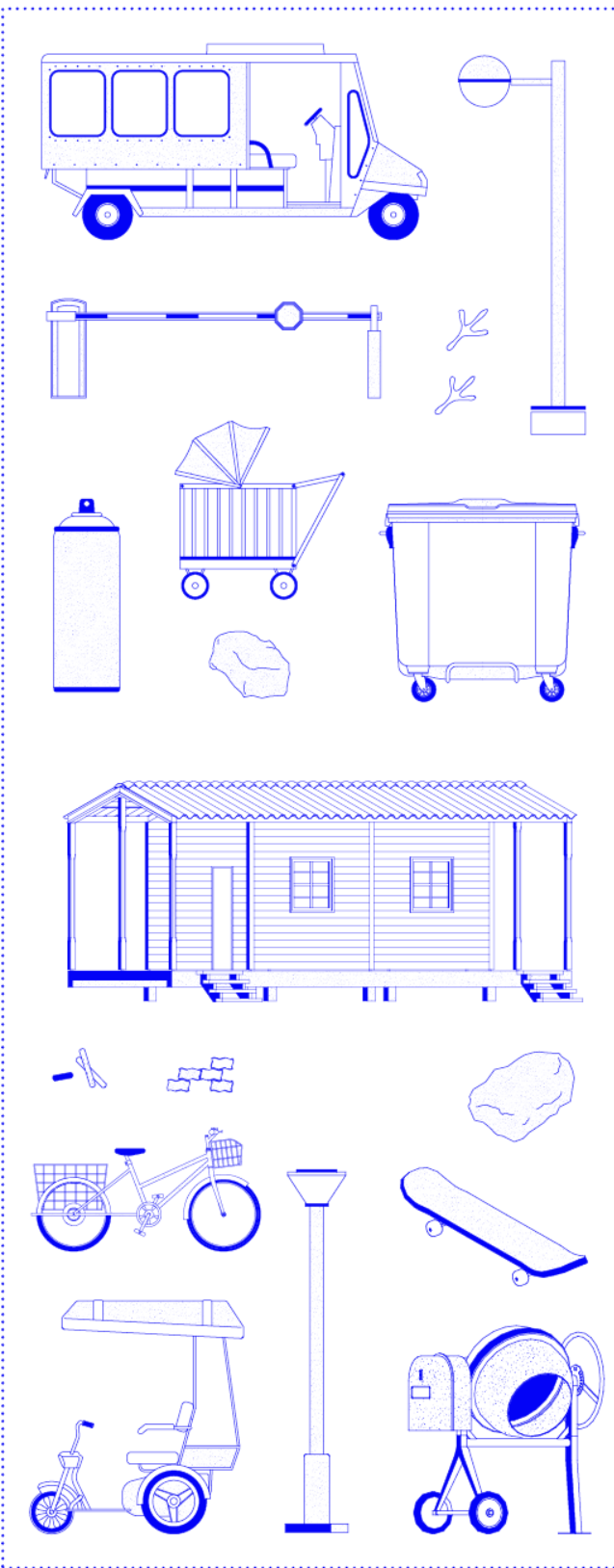

Addressing the public body through
Pavements: Act II

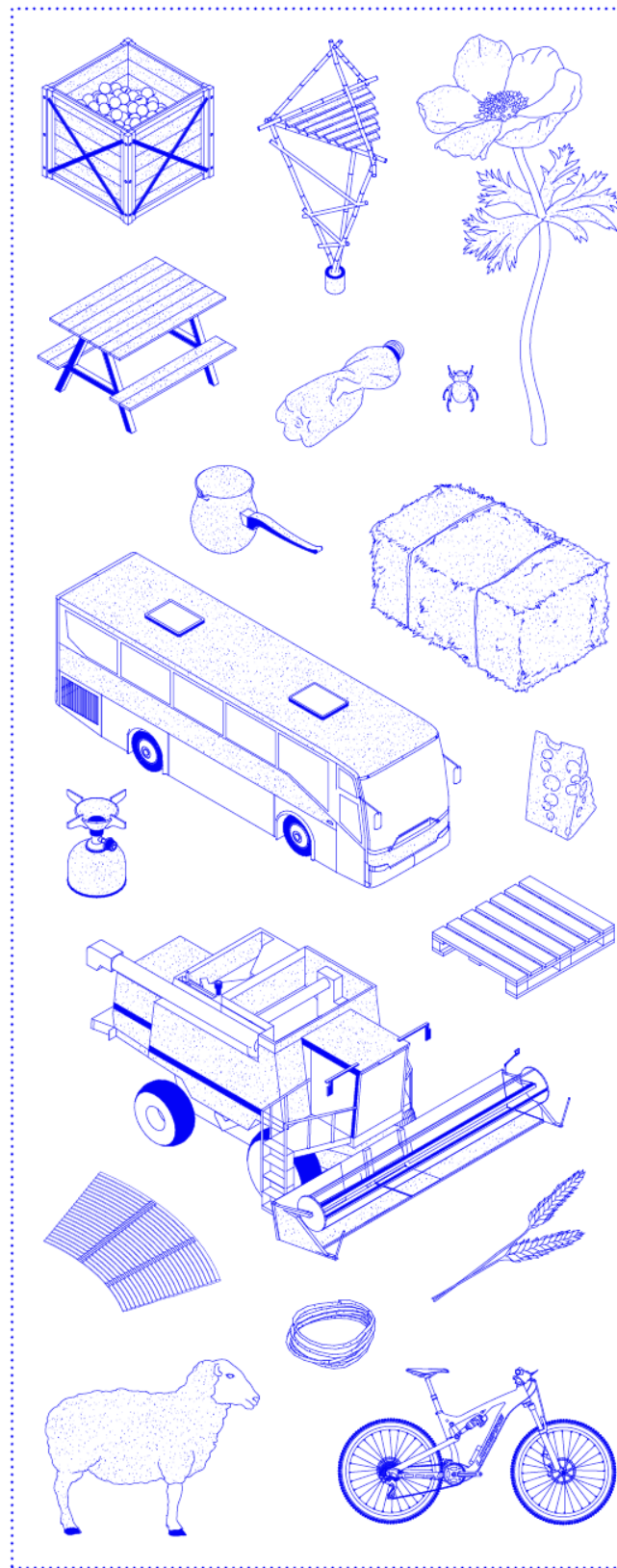

Addressing rural accountability through
Badlands: Act III

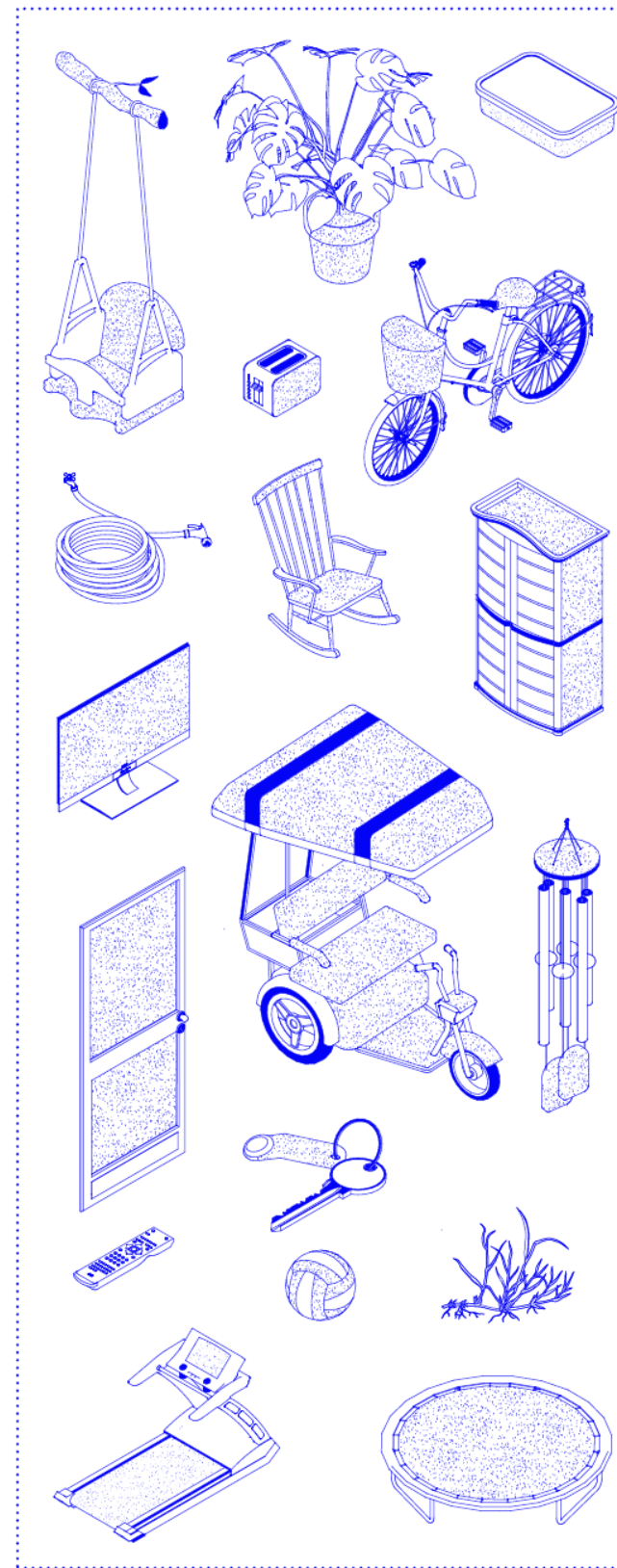

Addressing sociality through
Dwelling: Act IV

Addressing communality

Food: Act I

Intervention in the privatized dining hall aims to challenge the perception of equality through sameness at the heart of this institution. By creating variation of scales of usability and disrupting the linear spatial arrangement, it envisions a future of equality through difference.

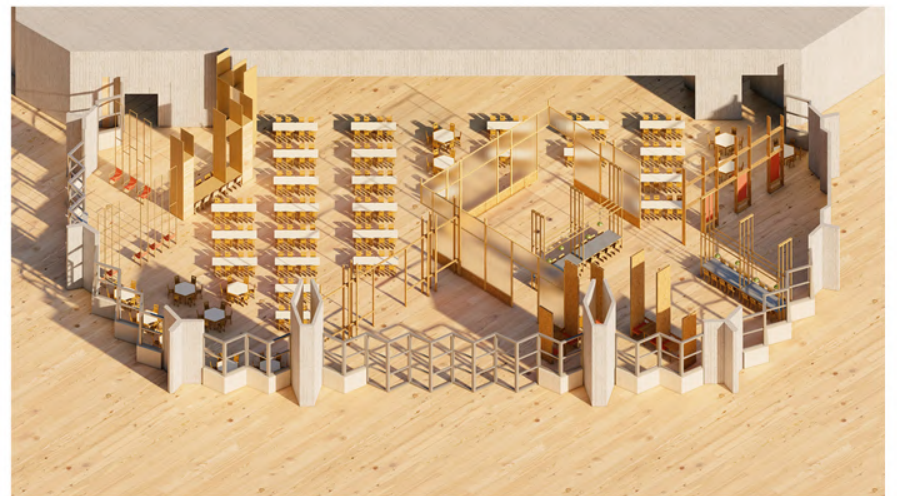
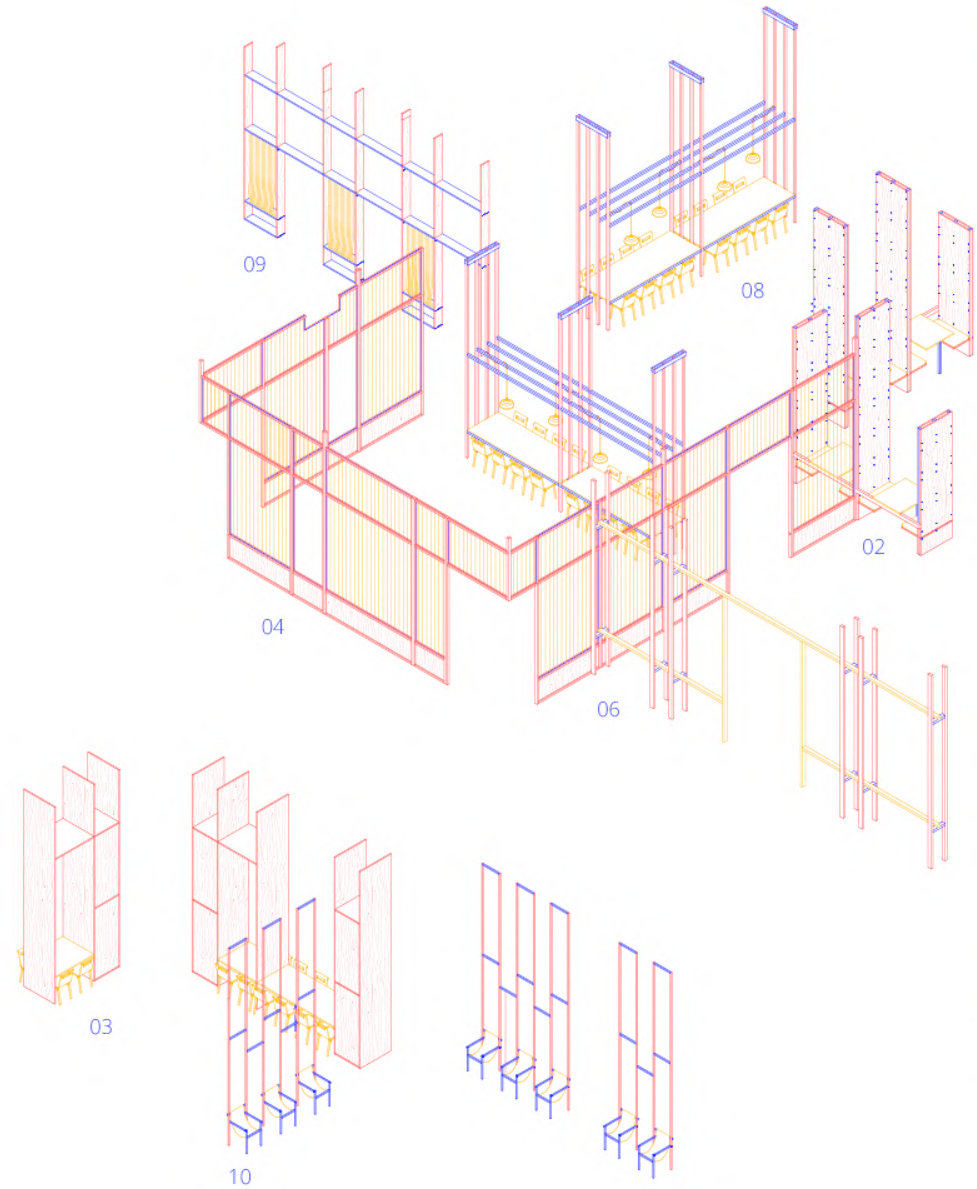
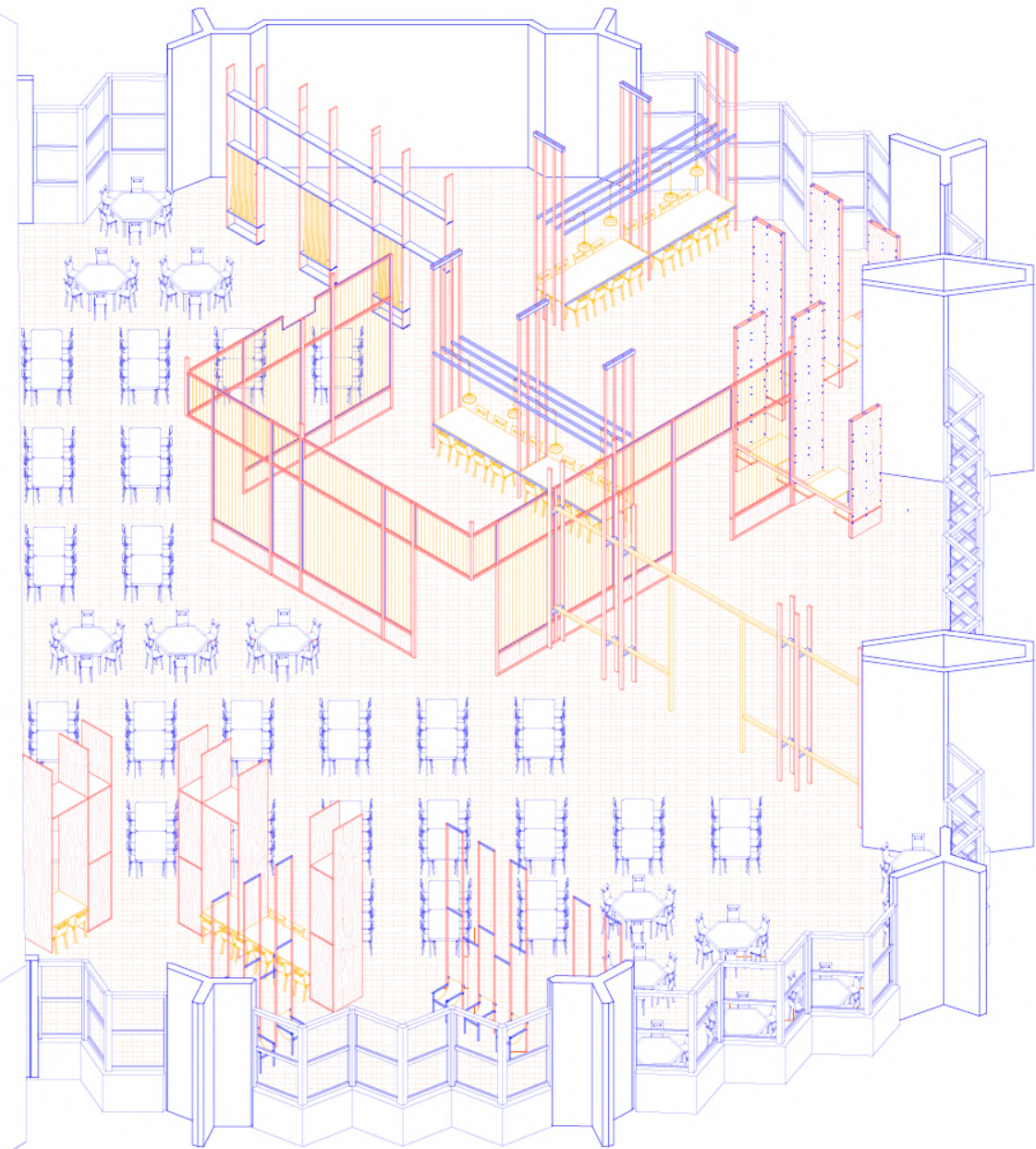
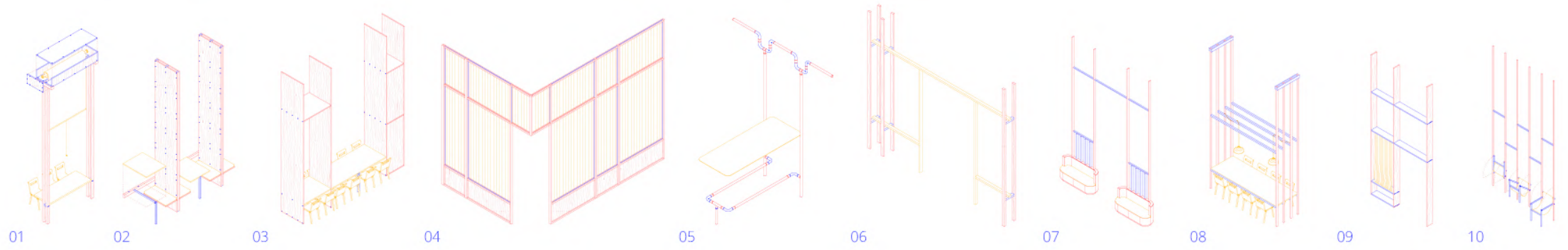

Reinterpreting the constructive grid, juxtaposing a diagonal grid on top of it and designing a system of active partitions segments the great hall into a series of smaller, more specific spaces.

The partition details are designed to add new levels of functionality and choice within the institution while still addressing the terms of communality by which it operates: eye contact, earshot and assembly.

Pavements: Act II

Demarcating three cross-kibbutz trails as a site challenges the perception of pavements as boundary lines, seeking instead to make connections. Reconstructing the old "Swedish Shack" as a steel frame, scattering it along the pavements and asking residents to envision its use creates a new scale for political and planning decisions within the kibbutz.

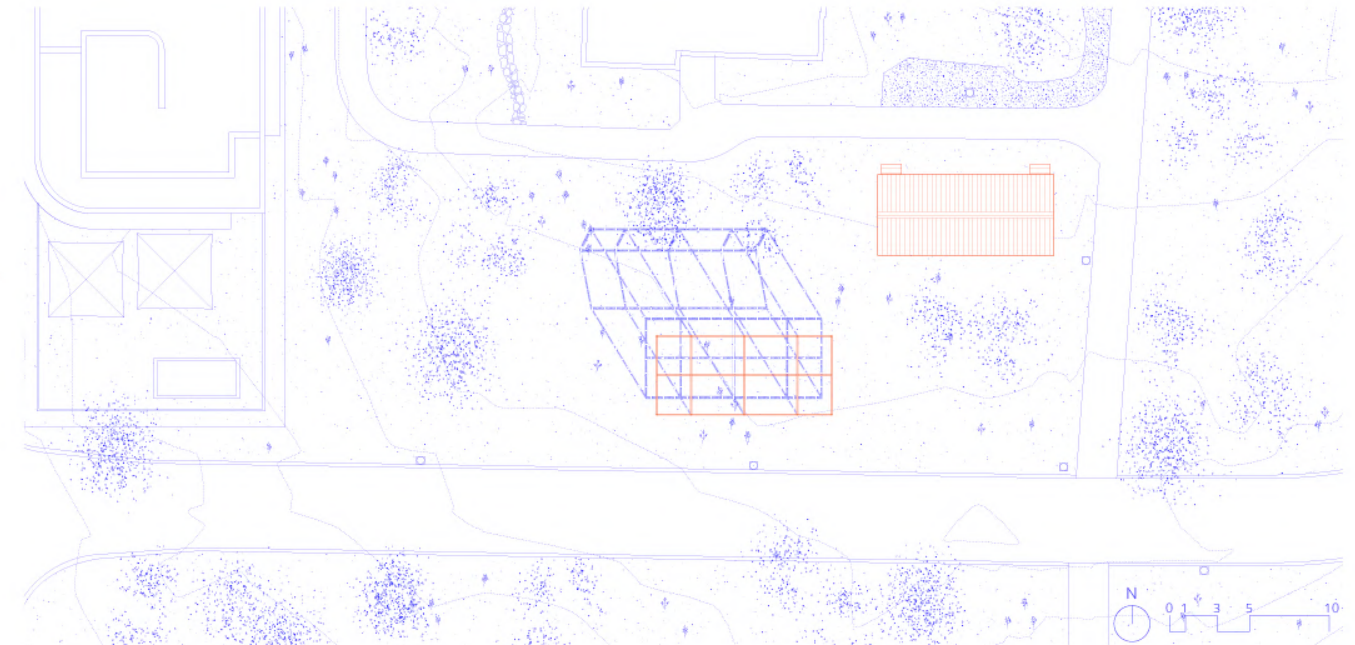
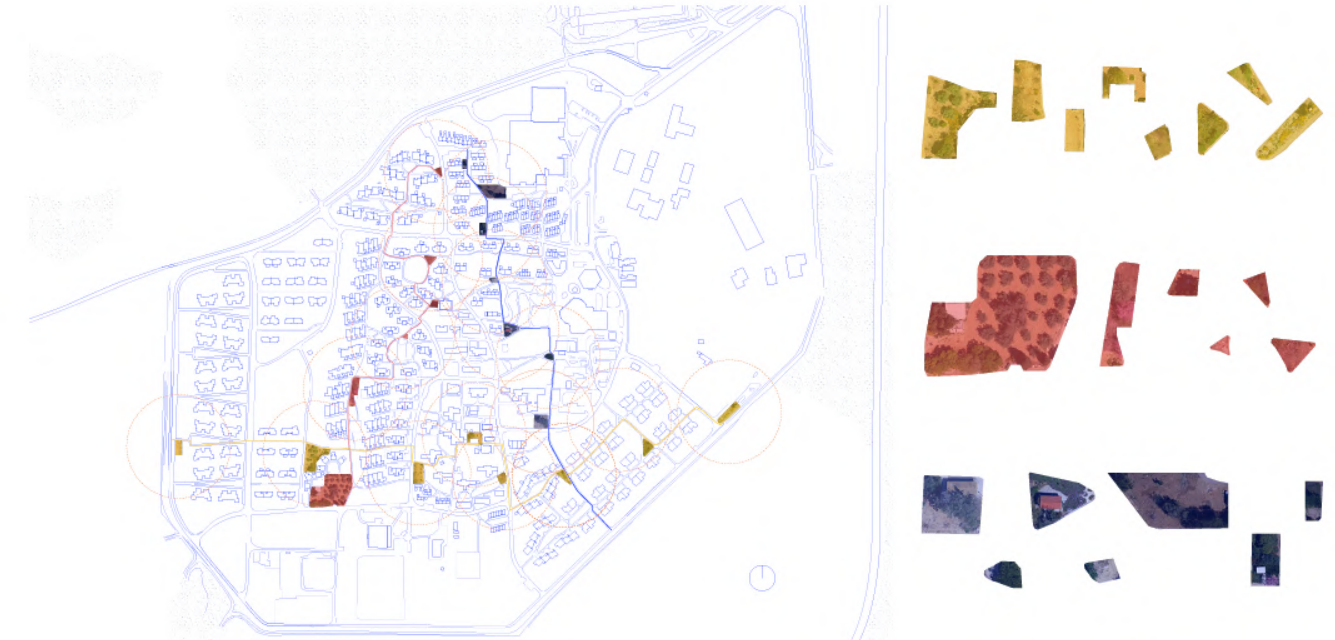
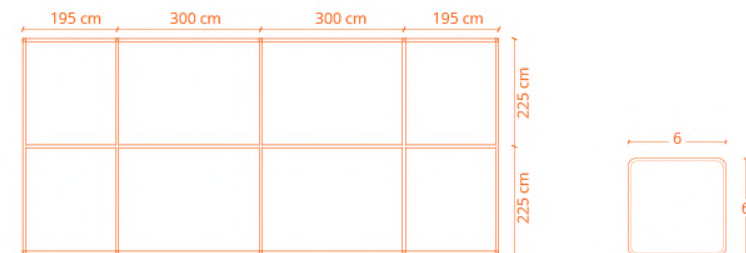
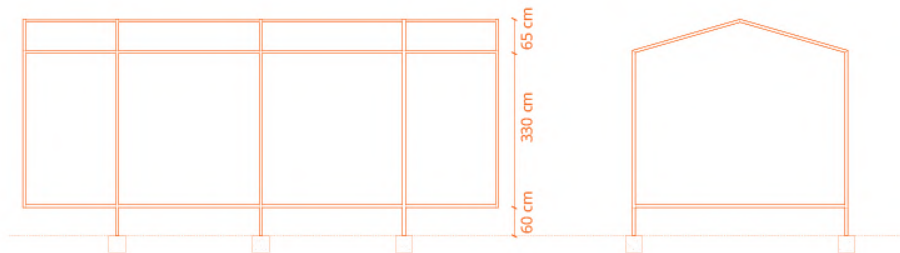
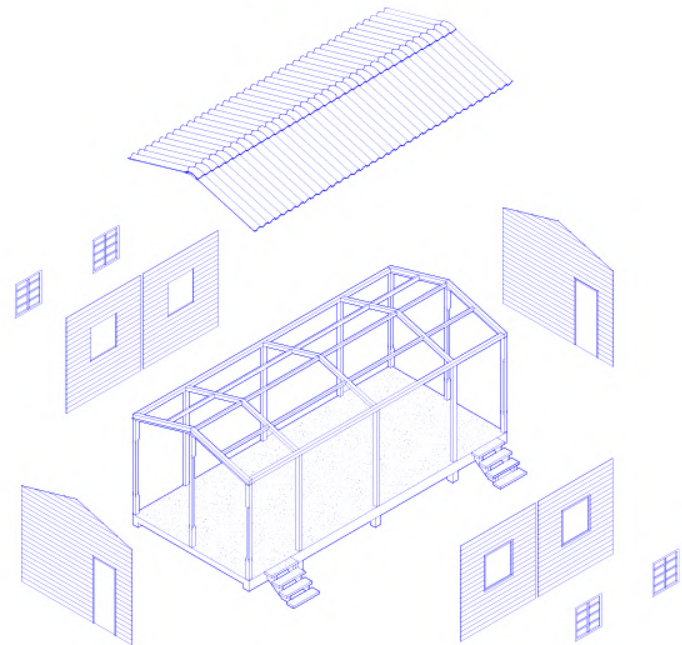
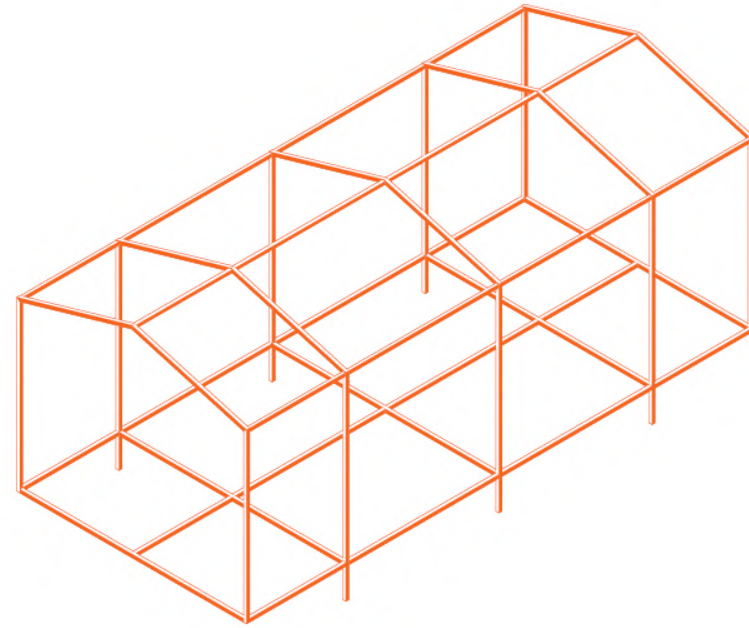
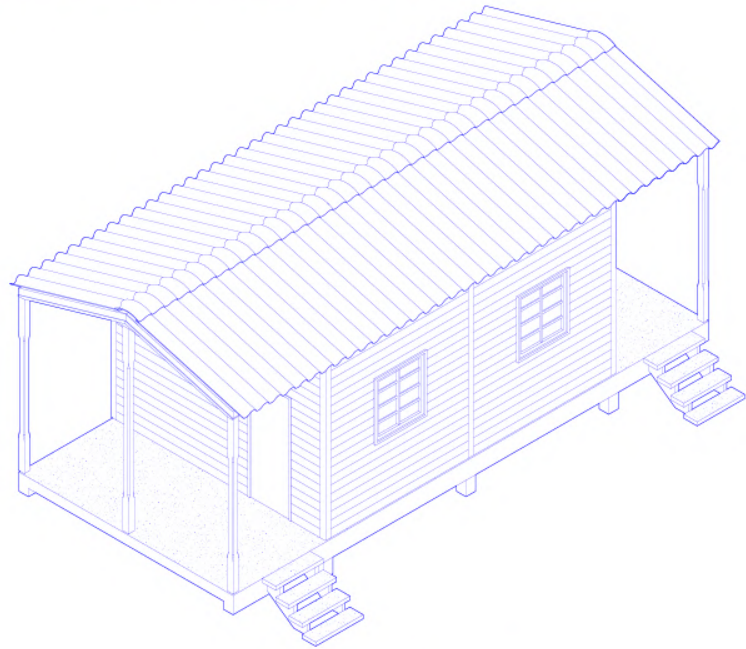

Badlands: Act III

By way of analyzing and listening to the open lands adjacent to the kibbutz, following the various actors and elements in play, this intervention seeks to create an intermediate zone between in and out, extending environmental accountability without claiming ownership or excluding users - simply providing shade, water, shelter and tempo-spatial framework.

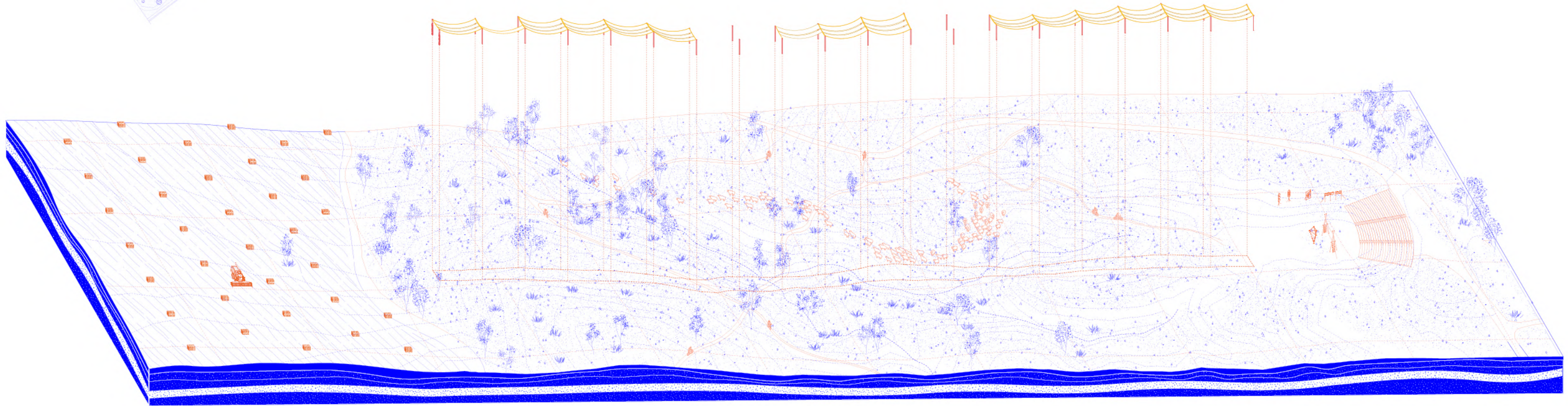
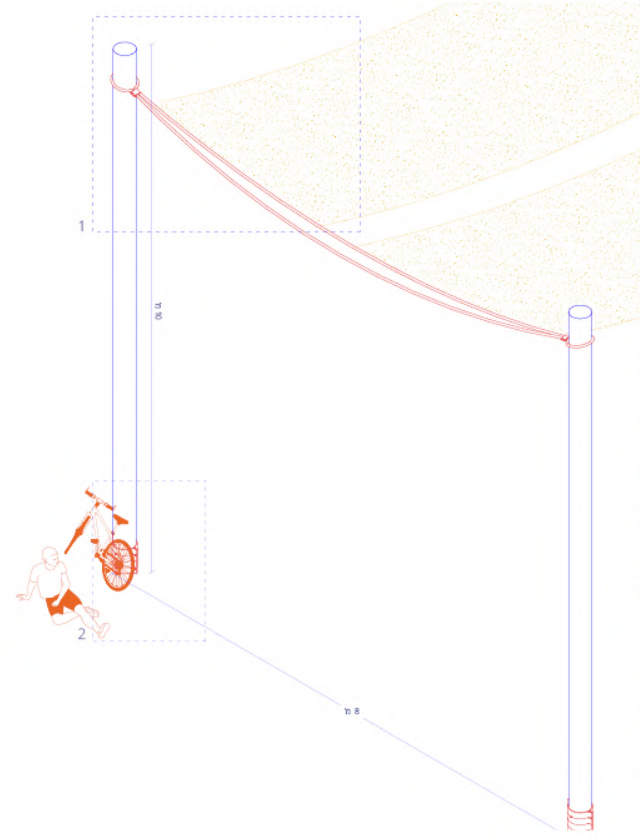
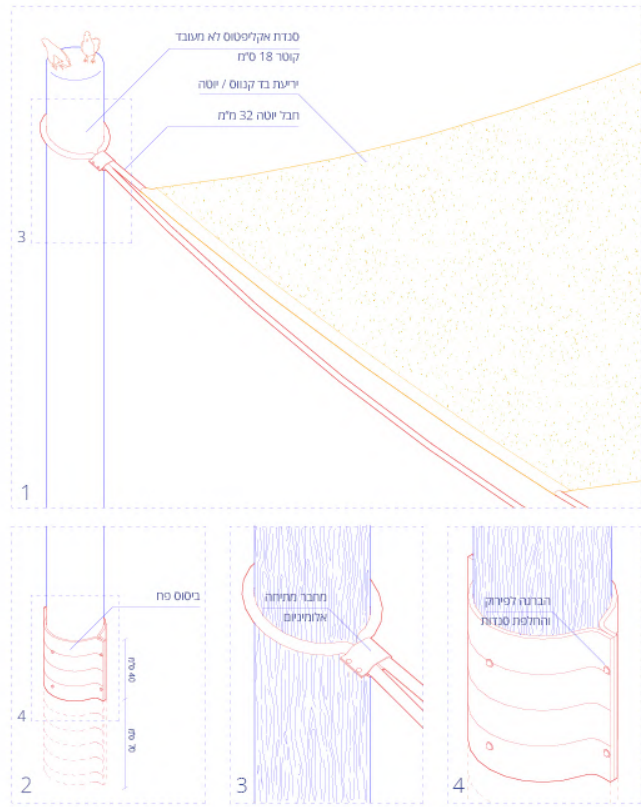
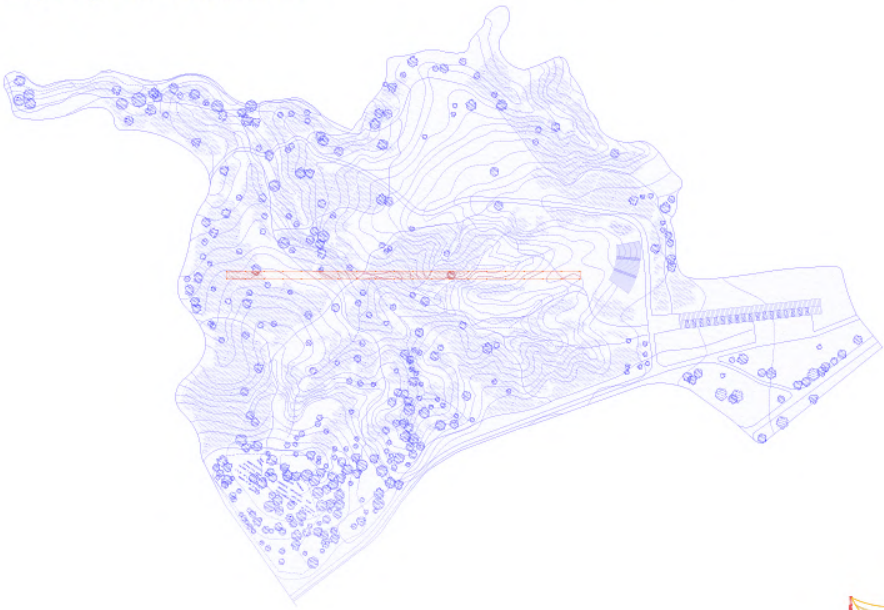

Addressing sociality

Dwelling: Act IV

This plan introduces a novel typology for living and socializing on the kibbutz. In response to the expansion logic by which the kibbutz evolves, this plan inserts dwelling inside the existing kibbutz, materializing by duplicating the pavement above street-level and planning the units from the public space inwards with various filter layers to create a gradation between shared and private.

The existing kibbutz divides neighbourhoods by age and seniority, determining a linear life-cycle through four housing types. Instead of this linear logic, this plan aims to include many different users under one roof, arranging the units according to a flexible module.

